

Design of indicators for the detection of time shift failures in $(\max, +)$ -linear systems

Alexandre Sahuguède, Euriell Le Corrond, Yannick Pencolé

► **To cite this version:**

Alexandre Sahuguède, Euriell Le Corrond, Yannick Pencolé. Design of indicators for the detection of time shift failures in $(\max, +)$ -linear systems. 20th IFAC World Congress, Jul 2017, Toulouse, France. pp.7P. hal-01534552

HAL Id: hal-01534552

<https://hal.laas.fr/hal-01534552>

Submitted on 7 Jun 2017

HAL is a multi-disciplinary open access archive for the deposit and dissemination of scientific research documents, whether they are published or not. The documents may come from teaching and research institutions in France or abroad, or from public or private research centers.

L'archive ouverte pluridisciplinaire **HAL**, est destinée au dépôt et à la diffusion de documents scientifiques de niveau recherche, publiés ou non, émanant des établissements d'enseignement et de recherche français ou étrangers, des laboratoires publics ou privés.



Design of indicators for the detection of time shift failures in $(max, +)$ -linear systems

Alexandre Sahuguède¹ and Euriell Le Corrond¹ and Yannick Pencolé¹

¹LAAS-CNRS, Université de Toulouse, CNRS, UPS, Toulouse, France

Abstract

In this paper, we address the problem of failure detection in a timed discrete event system (TDES). We first introduce the problem of detecting time shift failures in a TDES modeled as a $(max, +)$ -linear system. Then we propose the definition of an indicator that relies on the $(max, +)$ algebraic framework and show how it can detect time shift failures in the case of a single output system. Finally, an extension is proposed to deal with multiple outputs.

Keywords: Fault detection, Fault diagnosis, Modelling, $(max, +)$ -Linear Systems, Monitoring, Algebraic approaches.

1 Introduction

This paper addresses the problem of fault monitoring in a timed discrete event system (TDES). Given a flow of timed observations, the problem consists in determining whether the flow of observations results from a normal behavior of the system or an abnormal behavior. The problem of fault diagnosis and monitoring has been extensively investigated in untimed discrete event systems (see [Zaytoon and Lafortune, 2013] for a recent survey). However these contributions do not take into account time as an observable quantity. There are a few monitoring approaches that deal with time. The contributions of [Dousson and Duong, 1999; Pencolé and Subias, 2009; Saddem and Philippot, 2014] are based on formalisms like the chronicles or the causal temporal signatures: these formalisms model partially ordered set of observable events with time constraints. The acquisition of such models can come from the expertise or from automated learning techniques ([Subias et al., 2014]). In [Tripakis, 2002] and [Bouyer et al., 2005], the definition of the fault diagnosis problem is based on timed automata. Finally, other contributions are also based on time Petri nets ([Ghazel et al., 2009]; [Jiroveanu et al., 2013]; [Liu et al., 2014]).

In this paper, we propose to introduce a new way to solve the failure detection problem in TDES by using $(max, +)$ algebraic techniques ([Baccelli et al., 1992]; [Cohen et al., 1989]). The systems that are considered are timed discrete event systems such as manufacturing systems (for instance assembly lines), transportation systems (for instance airport luggage conveyors)... The type of failures that are considered are time shifts, that

is: given the flow of observations, how to detect that an unobservable event has occurred on time or with an unexpected positive/negative time shift (*i.e.* delay in the availability of a piece of equipment in an assembly line, unexpected delays for luggage delivery in the network of conveyors...). We propose to solve this problem on $(max, +)$ -linear systems that are a subclass of TDES that is well-suited to model systems like mentioned above. To perform failure detection, we propose to design indicators for $(max, +)$ -linear systems that aim at analyzing the current flow of observations and asserting about the presence or the absence of time shift failures within the system. The proposed indicators are defined with $(max, +)$ dioid operators.

The paper is organized as follows. Section 2 summarizes the necessary mathematical background about $(max, +)$ -linear systems. Section 3 introduces the problem of comparing time event flows within $(max, +)$ -linear systems. Section 4 then defines the proposed indicator in the specific case where the system has one output only. Section 5 finally extends the definition to the multiple outputs case.

2 Background on $(max, +)$ -Linear Systems

This section recalls the mathematical background that will be used throughout the paper. Basically, the studied TDES are modeled as $(max, +)$ -linear systems and the time shift detection problem will be solved with the residuation theory. For this section, interested reader is invited to peruse [Baccelli et al., 1992, Chap 4] and [MaxPlus, 1991].

2.1 Dioid theory

Definition 1 (Idempotent semiring). An idempotent semi-ring \mathcal{D} is a set endowed with two inner operations denoted \oplus and \otimes . The sum \oplus is associative, commutative, idempotent (*i.e.* $\forall a \in \mathcal{D}, a \oplus a = a$) and admits a neutral element denoted ε . The product¹ \otimes is associative, distributes over the sum and accepts ε as neutral element.

An idempotent semiring is said to be complete if it is closed for infinite sums and if the product distributes over infinite sums too. Moreover, due to the

¹As in usual algebra, \otimes will be omitted when no confusion is possible.

sum idempotency, an order relation can be associated with \mathcal{D} by the following equivalences: $\forall a, b \in \mathcal{D}$, $a \succeq b \iff (a = a \oplus b \text{ and } b = a \wedge b)$. Because of the lattice properties of a complete idempotent semiring, $a \oplus b$ is the least upper bound of \mathcal{D} whereas $a \wedge b$ is its greatest lower bound. Finally, the *Kleene star* operator is defined as follows: $a^* = \bigoplus_{i \geq 0} a^i$ with $a^0 = e$.

Theorem 2 ([MaxPlus, 1991]). *Implicit equation $x = ax \oplus b$, defined over a complete dioid \mathcal{D} , admits $x = a^*b$ as least solution.*

Example 3. The set $\overline{\mathbb{Z}}_{max} = \mathbb{Z} \cup \{-\infty, +\infty\}$, endowed with the max operator as sum \oplus and the classical sum as product \otimes , is a complete idempotent semiring where $\varepsilon = -\infty$, $e = 0$ and $T = +\infty$. On $\overline{\mathbb{Z}}_{max}$, the greatest lower bound \wedge takes the sense of the min operator.

Example 4. The set of formal series with two commutative variables γ and δ , Boolean coefficients in $\{\varepsilon, e\}$ and exponents in \mathbb{Z} , is a complete idempotent semiring denoted $\mathbb{B}[[\gamma, \delta]]$ where $\varepsilon = \bigoplus_{n,t \in \mathbb{Z}} \varepsilon \gamma^n \delta^t$ (null series) and $e = \gamma^0 \delta^0$. A series $s \in \mathbb{B}[[\gamma, \delta]]$ is written in a single way by $s = \bigoplus_{n,t \in \mathbb{Z}} s(n,t) \gamma^n \delta^t$ where $s(n,t) = e$ or ε .

Graphically, a series of $\mathbb{B}[[\gamma, \delta]]$ is described by a collection of points of coordinates (n,t) in \mathbb{Z}^2 with γ as horizontal axis and δ as vertical axis. Boolean coefficients indicate the presence of a point $s(n,t) = e$ or its absence $s(n,t) = \varepsilon$.

Example 5. The quotient set of $\mathbb{B}[[\gamma, \delta]]$ by the modulo $\gamma^*(\delta^{-1})^*$ equivalence relation provides the complete idempotent semiring $\mathcal{M}_{in}^{ax}[[\gamma, \delta]]$. This means that an element of $\mathcal{M}_{in}^{ax}[[\gamma, \delta]]$ is an equivalence class denoted² $[a]_{\gamma^*(\delta^{-1})^*}$ gathering all the elements of $\mathbb{B}[[\gamma, \delta]]$ equivalent modulo $\gamma^*(\delta^{-1})^*$. Neutral elements ε and e are identical to those of $\mathbb{B}[[\gamma, \delta]]$.

Graphically, the product of a monomial $\gamma^n \delta^t \in \mathbb{B}[[\gamma, \delta]]$ by $\gamma^*(\delta^{-1})^*$ goes to consider this element in $\mathcal{M}_{in}^{ax}[[\gamma, \delta]]$ as a southeast cone with coordinates (n,t) containing all the monomials equivalent to $\gamma^n \delta^t$. The description of all the points of all the cones induced by the monomials of a series $s \in \mathcal{M}_{in}^{ax}[[\gamma, \delta]]$ corresponds to the *maximal representation* of s . Its *minimal representation* is obtained by writing only the monomials representing the cones' vertices. Another interesting representation is the *dater representation* obtained from the maximal representation by writing for each γ^n of the series, the greatest corresponding δ^t .

Let $s = \gamma^0 \delta^3 \oplus \gamma^2 \delta^4 \oplus \gamma^5 \delta^7$ be a series of $\mathcal{M}_{in}^{ax}[[\gamma, \delta]]$, Figure 1 shows its maximal representation (all the points of the figure) and its dater representation (only the filled points on the lines). Let us remark that because of equivalence $\gamma^*(\delta^{-1})^*$, $s = \gamma^0 \delta^3 \oplus \gamma^2 \delta^4 \oplus \gamma^5 \delta^7 = \gamma^0 \delta^3 \oplus \gamma^1 \delta^3 \oplus \gamma^2 \delta^4 \oplus \gamma^3 \delta^4 \oplus \gamma^4 \delta^4 \oplus \gamma^5 \delta^7 \oplus \gamma^6 \delta^7$ (some points are covered by others as $\gamma^1 \delta^3$ by $\gamma^0 \delta^3$).

2.2 Residuation theory

Residuation is a general notion in lattice theory which allows for the definition of "pseudo-inverse" of some isotone maps. In particular, the residuation theory provides optimal solutions to inequalities such as $f(x) \preceq b$,

²Notation a without the bracket will be adopted in the sequel.

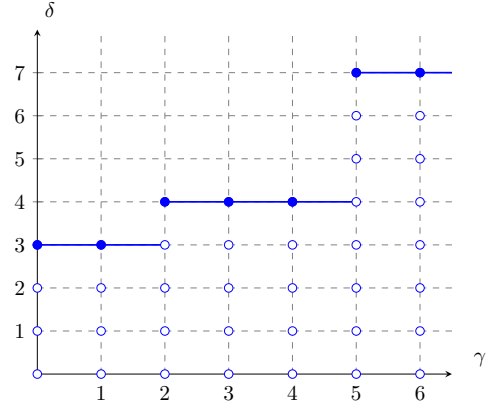

Figure 1: Maximal and dater representations of a series $s \in \mathcal{M}_{in}^{ax}[[\gamma, \delta]]$.

where f is an order-preserving mapping defined over ordered sets. This theory can then be applied over idempotent semiring as follows.

Definition 6 (Residuated and residual mapping). Let $f : \mathcal{D} \rightarrow \mathcal{C}$ be an isotone mapping, where \mathcal{D} and \mathcal{C} are complete idempotent semirings. Mapping f is said to be *residuated* if $\forall b \in \mathcal{C}$, the greatest element of subset $\{x \in \mathcal{D} \mid f(x) \preceq b\}$, denoted $f^\sharp(b)$, exists and belongs to this subset. Mapping f^\sharp is called the *residual* of f .

When f is residuated, f^\sharp is the unique isotone mapping such that $f \circ f^\sharp \preceq \text{Id}_{\mathcal{C}}$ and $f^\sharp \circ f \succeq \text{Id}_{\mathcal{D}}$, where $\text{Id}_{\mathcal{C}}$ and $\text{Id}_{\mathcal{D}}$ are respectively the identity mappings on \mathcal{C} and \mathcal{D} .

Example 7. Mapping $R_a : x \mapsto x \otimes a$ defined over a complete idempotent semiring \mathcal{D} is residuated. Its residual is usually denoted $R_a^\sharp : x \mapsto x \phi a$ and called *right quotient*. Therefore, $b \phi a$ is the greatest solution to inequality $x \otimes a \preceq b$, i.e. $b \phi a = \hat{x} = \bigoplus \{x \mid x \otimes a \preceq b\}$. This example can be applied for the product of matrices such as $X \mapsto X \otimes A \in \mathcal{D}^{p \times m}$ with $A \in \mathcal{D}^{n \times m}$ and $X \in \mathcal{D}^{p \times n}$, that is:

$$R_A = X \otimes A : (X \otimes A)_{ij} = \bigoplus_{k=1}^n X_{ik} \otimes A_{kj}.$$

and the computation of $B \phi A \in \mathcal{D}^{p \times n}$ with $B \in \mathcal{D}^{p \times m}$ is given by:

$$R_A^\sharp(B) = B \phi A : (B \phi A)_{ij} = \bigwedge_{k=1}^m B_{ik} \phi A_{jk}. \quad (1)$$

Theorem 8 ([MaxPlus, 1991]). *Let \mathcal{D} be a complete dioid and $A \in \mathcal{D}^{n \times m}$ be a matrix. Then, $A \phi A \in \mathcal{D}^{n \times n}$ is a matrix which verifies*

$$A \phi A = (A \phi A)^*. \quad (2)$$

2.3 Models of (max,+)-linear systems

The complete idempotent semiring $\mathcal{M}_{in}^{ax}[[\gamma, \delta]]$ aims at modeling TDES as flows of events over time while keeping the history of their occurrences. Indeed, in a series of $\mathcal{M}_{in}^{ax}[[\gamma, \delta]]$, a monomial $\gamma^n \delta^t$ is interpreted as follows: *the n^{th} event occurs at earliest at time t* . Equivalence $\gamma^*(\delta^{-1})^*$ deals with obtaining weakly increasing series

which ensures the conservation of information about previous events with their times.

Typical systems that can be modeled within this formal framework are automated assembly lines, box conveyors. . . Given a flow u of input timed events (the presence of a new element to be processed in the assembly line, a new box in the conveyor. . .), the system's response is indeed a flow y of output timed events (delivery of a final product at the end of the assembly line, delivery of a box to its destination. . .).

The relationship between the inputs u and the outputs y of the system is given by the following equation:

$$y = h \otimes u \quad (3)$$

where h is its transfer function.

To be more specific, obtaining this input/output relation comes from the following state representation:

$$\begin{cases} x = Ax \oplus Bu \\ y = Cx \end{cases} \quad (4)$$

where $A \in \mathcal{M}_{in}^{ax}[\gamma, \delta]^{n \times n}$, $B \in \mathcal{M}_{in}^{ax}[\gamma, \delta]^{n \times p}$ and $C \in \mathcal{M}_{in}^{ax}[\gamma, \delta]^{q \times n}$ while n , p and q refer respectively to the state vector size of the system (x), the input vector size (u) and the output vector size (y). Then, by applying Theorem 2 the input/output relation is obtained $y = CA^*Bu = hu$. So $h = CA^*B$.

Systems that are fully characterized by Equation (3) or Equation (4) are commonly called (*max, +*)-linear systems. Moreover, a C++ library called `minmaxgd` enables series of $\mathcal{M}_{in}^{ax}[\gamma, \delta]$ to be handled (see [Cottenceau et al., 2000]).

Example 9. Consider an automated assembly line with 3 machines M_1 , M_2 and M_3 graphically modeled in Figure 2 by a Timed Event Graph³ (TEG). Machines M_1 and M_2 independently process respectively incoming parts u_1 and u_2 . For each incoming part, the duration of the process is 2 for machine M_1 and 3 for machine M_2 . The end of the processing of machines M_1 and M_2 is respectively represented by the firing of transition x_2 and x_4 . Machine M_3 then assembles one part coming from machine M_1 with one part coming from machine M_2 , taking respectively 3 and 5 time units to arrive there. The firing of transition x_6 represents the end of the assembling process. Two assembling processes can be done at the same time and the duration of this process is 2 time units. The complete product is then delivered as the output y of the line.

The matrices A , B and C of the state representation of this MISO (Multiple Inputs - Single Output) system is given in $\mathcal{M}_{in}^{ax}[\gamma, \delta]$:

$$A = \begin{pmatrix} \cdot & \gamma^1 \delta^0 & \cdot & \cdot & \cdot & \cdot \\ \gamma^0 \delta^2 & \cdot & \cdot & \cdot & \cdot & \cdot \\ \cdot & \cdot & \cdot & \gamma^1 \delta^0 & \cdot & \cdot \\ \cdot & \cdot & \gamma^0 \delta^3 & \cdot & \cdot & \cdot \\ \cdot & \gamma^0 \delta^3 & \cdot & \gamma^0 \delta^5 & \cdot & \gamma^2 \delta^0 \\ \cdot & \cdot & \cdot & \cdot & \gamma^0 \delta^2 & \cdot \end{pmatrix}, B = \begin{pmatrix} \gamma^0 \delta^0 & \cdot \\ \cdot & \gamma^0 \delta^0 \\ \cdot & \cdot \\ \cdot & \cdot \\ \cdot & \cdot \end{pmatrix}$$

³Subclass of Timed Petri Net in which each place has exactly one upstream and one downstream transition. In TEG, the earliest firing rule is applied and corresponds to the use of the least solution in the transfer function.

$$C = (\cdot \quad \cdot \quad \cdot \quad \cdot \quad \cdot \quad \gamma^0 \delta^0).$$

In the entries of matrices, the grade of γ shows the backward event shift between transitions (the $n + 1^{th}$ firing of x_1 depends (not only) on the n^{th} firing of x_2) and the grade of δ shows the backward time shift between transitions (the firing date of x_2 depends on the firing date of x_1 plus 2 time units). The point '.' denotes ε in the matrices (meaning the absence of connection between transitions).

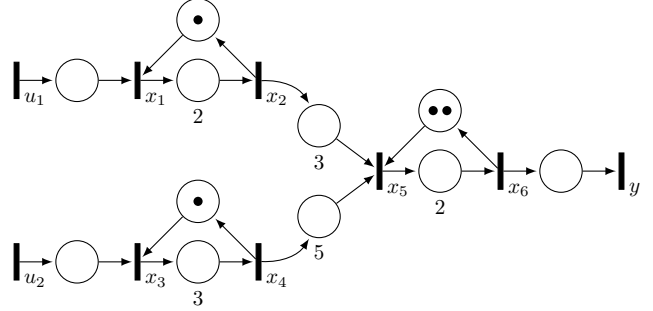

Figure 2: A TEG of an automated assembly line.

The transfer function (which is actually a matrix $h \in \mathcal{M}_{in}^{ax}[\gamma, \delta]^{q \times p}$ with $q = 1$) of the system is computed:

$$h = CA^*B = (\gamma^0 \delta^7 (\gamma^1 \delta^2)^* \quad \gamma^0 \delta^{10} (\gamma^1 \delta^3)^*).$$

So, if the following input is given:

$$u = \begin{pmatrix} \gamma^0 \delta^2 \oplus \gamma^1 \delta^3 \oplus \gamma^2 \delta^5 \oplus \gamma^4 \delta^{+\infty} \\ \gamma^0 \delta^2 \oplus \gamma^1 \delta^3 \oplus \gamma^2 \delta^5 \oplus \gamma^4 \delta^{+\infty} \end{pmatrix}$$

the corresponding output is:

$$y = hu = \gamma^0 \delta^{12} \oplus \gamma^1 \delta^{15} \oplus \gamma^2 \delta^{18} \oplus \gamma^3 \delta^{21} \oplus \gamma^4 \delta^{+\infty}.$$

Input u and output y illustrate very well the notion of flows of events over time with the history of their occurrences. In these flows also called trajectories, the numbering of event starts at 0. By taking the example of u_1 and its monomial $\gamma^0 \delta^2$, this means that the 0^{th} event (that is the first event of the trajectory) occurs at time 2. When trajectories describe a finite number of production orders or a finite number of treated boxes, they contain a finite number of monomials in which the last monomial is written $\gamma^n \delta^{+\infty}$. This last monomial means that the n^{th} event never happens (4^{th} event in u and y).

3 Time comparison between flows

As presented in Subsection 2.3, (*max, +*)-linear systems are fully characterized by the transfer function h . The relationship between the inputs u and the outputs y of the system is actually the functional model of the system. A system is said to be failing as soon as the function of the system does not properly operate, that is as soon as the real output flow of events y does not match the expected output flow \tilde{y} . Suppose now that both y and \tilde{y} are known, the challenge is to find a way to actually compare y and \tilde{y} and determine the presence of time shifts between y and \tilde{y} .

We propose here to perform this comparison by using the residuation theory in particular the use of the

right quotient ϕ . Let $s \in \mathcal{M}_{in}^{ax}[\gamma, \delta]$ be a series, the *dater function* of s is the non-decreasing function $\mathcal{D}_s(n)$ from \mathbb{Z} to \mathbb{Z} such that $s = \bigoplus_{n \in \mathbb{Z}} \gamma^n \delta^{\mathcal{D}_s(n)}$. The proposed comparison then relies on the use of a time shift function.

Definition 10 (Time shift function). Let $a, b \in \mathcal{M}_{in}^{ax}[\gamma, \delta]$ and their respective dater functions $\mathcal{D}_a(n)$ and $\mathcal{D}_b(n)$, the *time shift function* representing the time shifts between a and b for each $n \in \mathbb{Z}$ is defined by $\mathcal{T}_{a,b}(n) = \mathcal{D}_a(n) - \mathcal{D}_b(n)$.

Intuitively speaking, the time shift function associates the time difference between the occurrence of the n^{th} event of series a and the occurrence of the n^{th} event of series b . Obviously, $\mathcal{T}_{a,a}(n) = 0, \forall n \in \mathbb{Z}$.

Theorem 11 ([MaxPlus, 1991]). Let $a, b \in \mathcal{M}_{in}^{ax}[\gamma, \delta]$, the time shift function can be bounded as follows:

$$\forall n \in \mathbb{Z}, \quad \mathcal{D}_{b\phi a}(0) \leq \mathcal{T}_{a,b}(n) \leq -\mathcal{D}_{a\phi b}(0).$$

The lower bound is the minimal shift in the time domain between a and b whereas the upper bound is the maximal shift.

Theorem 11 asserts that the comparison between series a and b can be reduced to determine the bounds $\mathcal{D}_{b\phi a}(0)$ and $-\mathcal{D}_{a\phi b}(0)$ of their time function $\mathcal{T}_{a,b}$. These bounds can be extracted from the series $b\phi a$ and $a\phi b$. More specifically, by writing these bounds back in series of $\mathcal{M}_{in}^{ax}[\gamma, \delta]$:

$$\begin{aligned} \mathcal{D}_{b\phi a}(0) &\text{ comes from } \gamma^0 \delta^{\mathcal{D}_{b\phi a}(0)} \in b\phi a, \\ -\mathcal{D}_{a\phi b}(0) &\text{ comes from } \gamma^0 \delta^{\mathcal{D}_{a\phi b}(0)} \in a\phi b. \end{aligned}$$

These monomials might not appear explicitly in series $a\phi b$ and $b\phi a$, however they can be revealed by writing them into their dater representations in which each grade of γ present in the series is written.

Example 12. For instance, let $a, b \in \mathcal{M}_{in}^{ax}[\gamma, \delta]$ such that:

$$\begin{aligned} a &= \gamma^0 \delta^{12} \oplus \gamma^1 \delta^{15} \oplus \gamma^2 \delta^{18} \oplus \gamma^3 \delta^{21} \oplus \gamma^4 \delta^{+\infty}, \\ b &= \gamma^0 \delta^{12} \oplus \gamma^1 \delta^{15} \oplus \gamma^2 \delta^{19} \oplus \gamma^3 \delta^{23} \oplus \gamma^4 \delta^{+\infty}. \end{aligned}$$

As illustrated in Figure 3, it is clear that the minimal time shift is equal to 0 (reached for γ^0 and γ^1) whereas the maximal time shift is equal to 2.

Computations of $a\phi b$ and $b\phi a$ provide mathematically these shifts:

$$\begin{aligned} a\phi b &= \gamma^0 \delta^{-2} \oplus \gamma^1 \delta^2 \oplus \gamma^2 \delta^6 \oplus \gamma^3 \delta^9 \oplus \gamma^4 \delta^{+\infty}, \\ b\phi a &= \gamma^0 \delta^0 \oplus \gamma^1 \delta^3 \oplus \gamma^2 \delta^7 \oplus \gamma^3 \delta^{11} \oplus \gamma^4 \delta^{+\infty}. \end{aligned}$$

The minimal time shift $\mathcal{D}_{b\phi a}(0)$ is equal to 0 and is found in the monomial $\gamma^0 \delta^{\mathcal{D}_{b\phi a}(0)}$ of $b\phi a$. This means that for at least one point, series a and b contain the same monomial ($\gamma^0 \delta^{12}$ and $\gamma^1 \delta^{15}$ to be specific). The maximal time shift $-\mathcal{D}_{a\phi b}(0)$ is equal to 2 and is found in the monomial $\gamma^0 \delta^{\mathcal{D}_{a\phi b}(0)}$ of $a\phi b$ and is illustrated in Figure 4. This means that the biggest distance between a and b in the vertical point of view is of 2 time units (between monomials $\gamma^3 \delta^{21} \in a$ and $\gamma^3 \delta^{23} \in b$ to be specific).

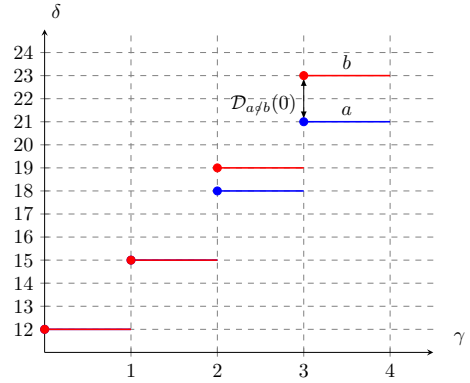

Figure 3: Series $a, b \in \mathcal{M}_{in}^{ax}[\gamma, \delta]$ in their dater representations.

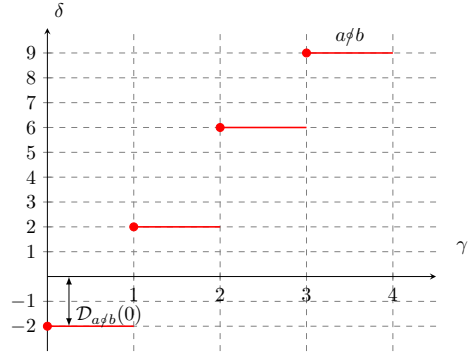

Figure 4: Maximal bound of the time shift between a and b .

Back to the problem of comparing the real output y of the system and its expected output \tilde{y} , Theorem 11 then provides a way to bound the possible time shifts between the events of y and \tilde{y} . More specifically, bounds on these time shifts are determined as follows.

Proposition 13 (Bounds on time shifts). Let y and $\tilde{y} \in \mathcal{M}_{in}^{ax}[\gamma, \delta]$, time shifts between y and \tilde{y} are in the following interval:

$$\Sigma_\tau(y, \tilde{y}) = [\mathcal{D}_{y\phi\tilde{y}}(0); -\mathcal{D}_{\tilde{y}\phi y}(0)] \quad (5)$$

where $\gamma^0 \delta^{\mathcal{D}_{y\phi\tilde{y}}(0)} \in y\phi\tilde{y}$ and $\gamma^0 \delta^{\mathcal{D}_{\tilde{y}\phi y}(0)} \in \tilde{y}\phi y$.

4 Indicator: the Single Output case

This section introduces a first failure indicator that can be implemented on $(max, +)$ -linear systems that are composed of a set of inputs u and one single output y (called MISO system for short). Figure 2 illustrates such a system. Only the inputs and the output of the system are observable. As stated in Subsection 2.3, the output of a $(max, +)$ -linear system is fully characterized by its transfer function h . By the observation of u , it is therefore possible to compute the expected output of the system, that is:

$$\tilde{y} = hu.$$

The indicator in charge of detecting time shift failures then computes the time shift bounds between the real observed output y and the expected output \tilde{y} .

Definition 14 (Indicator of an observed MISO system). Let $h \in \mathcal{M}_{in}^{ax}[[\gamma, \delta]]^{1 \times p}$ be the transfer function of a MISO (max, +)-linear system, let $u \in \mathcal{M}_{in}^{ax}[[\gamma, \delta]]^p$ and $y \in \mathcal{M}_{in}^{ax}[[\gamma, \delta]]$ be the observable input and output trajectories of the system, the indicator I_{SO} of the system is a function:

$$I_{SO}(u, y) = \begin{cases} \text{false} & \text{if for } \tilde{y} = hu, \Sigma_\tau(y, \tilde{y}) = [0; 0], \\ \text{true} & \text{otherwise.} \end{cases} \quad (6)$$

The indicator raises an alarm (*i.e.* it returns *true*) as soon as the minimal or the maximal time shift bounds determined by Proposition 13 between the observed output y and its expected counterpart \tilde{y} are not null. By returning *false* only when $\Sigma_\tau(y, \tilde{y}) = [0; 0]$, it is guaranteed that the indicator will return *false* only when these bounds are null. Now the remaining question is whether the defined indicator is correct or not.

Definition 15 (Correct indicator). An indicator is *correct* if it returns *true* only when the system is failing.

In other words, a correct indicator should never raise a signal, an alarm, as long as the system has no failure. A correct indicator ensures that there are no false positive detection alarms. For this specific indicator, it means that it is correct only if $\Sigma_\tau(y, \tilde{y}) \neq [0; 0]$ means the system is indeed failing.

Proposition 16. *The indicator $I_{SO}(u, y)$ is correct.*

Proof. To prove that $I_{SO}(u, y)$ is correct, we need to prove that for any couple of identical trajectories (y_1, y_2) in $\mathcal{M}_{in}^{ax}[[\gamma, \delta]]$, $\Sigma_\tau(y_1, y_2) = [0; 0]$. Let us consider two identical series y_1 and y_2 , then $y_1 \dot{\phi} y_2 = y_2 \dot{\phi} y_1 = y_1 \dot{\phi} y_1$. Now, let $x_1 = y_1 \dot{\phi} y_1$ and according to Theorems 8 and 2, $x_1 = (x_1)^* = e \oplus \dots = \gamma^0 \delta^0 \oplus \dots$. Therefore there always exists in $y_1 \dot{\phi} y_2$ and in $y_2 \dot{\phi} y_1$ a monomial $e = \gamma^0 \delta^0$. Thus from Theorem 11 we get $\mathcal{D}_{y_1 \dot{\phi} y_2}(0) = -\mathcal{D}_{y_2 \dot{\phi} y_1}(0) = 0$. By Equation (5) the result follows. \square

Example 17. Let us take back the MISO (max, +)-linear system of Figure 2. When the system is not failing, remember that for the following input:

$$u = \begin{pmatrix} \gamma^0 \delta^2 \oplus \gamma^1 \delta^3 \oplus \gamma^2 \delta^5 \oplus \gamma^4 \delta^{+\infty} \\ \gamma^0 \delta^2 \oplus \gamma^1 \delta^3 \oplus \gamma^2 \delta^5 \oplus \gamma^4 \delta^{+\infty} \end{pmatrix}$$

the expected output is:

$$\tilde{y} = hu = \gamma^0 \delta^{12} \oplus \gamma^1 \delta^{15} \oplus \gamma^2 \delta^{18} \oplus \gamma^3 \delta^{21} \oplus \gamma^4 \delta^{+\infty}.$$

Now, assume that there is a time failure from transition x_1 to transition x_2 that generates a delay of 2 time units (machine M_1 unexpectedly spends 4 time units to process instead of 2). The observed output is then:

$$y = \gamma^0 \delta^{12} \oplus \gamma^1 \delta^{15} \oplus \gamma^2 \delta^{19} \oplus \gamma^3 \delta^{23} \oplus \gamma^4 \delta^{+\infty}.$$

One can see that \tilde{y} and y are respectively equal to series a and b from Figure 3 so:

$$\begin{aligned} \tilde{y} \dot{\phi} y &= \gamma^0 \delta^{-2} \oplus \gamma^1 \delta^2 \oplus \gamma^2 \delta^6 \oplus \gamma^3 \delta^9 \oplus \gamma^4 \delta^{+\infty}, \\ y \dot{\phi} \tilde{y} &= \gamma^0 \delta^0 \oplus \gamma^1 \delta^3 \oplus \gamma^2 \delta^7 \oplus \gamma^3 \delta^{11} \oplus \gamma^4 \delta^{+\infty}. \end{aligned}$$

According to Proposition 13:

$$\Sigma_\tau(y, \tilde{y}) = [\mathcal{D}_{y \dot{\phi} \tilde{y}}(0); -\mathcal{D}_{\tilde{y} \dot{\phi} y}(0)] = [0; 2].$$

Then, by Definition 14, $I_{SO}(u, y) = \text{true}$, the time shift failure is detected.

5 Extension to the Mutiple Outputs case

The extension to the MIMO (Multiple Inputs Multiple Outputs) case can be done very naturally by the matrix computation of the right quotient given in Equation (1). A MIMO system is failing if at least one of its output is not the expected one. In a MIMO system, observed output y and expected output \tilde{y} are column vectors of size q , that is $y, \tilde{y} \in \mathcal{M}_{in}^{ax}[[\gamma, \delta]]^q$. So, the computations of $y \dot{\phi} \tilde{y}, \tilde{y} \dot{\phi} y \in \mathcal{M}_{in}^{ax}[[\gamma, \delta]]^{q \times q}$ become:

$$y \dot{\phi} \tilde{y} = \begin{pmatrix} y_1 \dot{\phi} \tilde{y}_1 & \cdots & y_1 \dot{\phi} \tilde{y}_q \\ \vdots & \ddots & \vdots \\ y_q \dot{\phi} \tilde{y}_1 & \cdots & y_q \dot{\phi} \tilde{y}_q \end{pmatrix},$$

and:

$$\tilde{y} \dot{\phi} y = \begin{pmatrix} \tilde{y}_1 \dot{\phi} y_1 & \cdots & \tilde{y}_1 \dot{\phi} y_q \\ \vdots & \ddots & \vdots \\ \tilde{y}_q \dot{\phi} y_1 & \cdots & \tilde{y}_q \dot{\phi} y_q \end{pmatrix}.$$

In these matrices, since we want to make comparisons between the outputs of identical indexes (observed output y_i with expected output \tilde{y}_i), the relevant elements for the computation of the MIMO indicator are the diagonal elements of the matrices corresponding to the autocorrelation of the outputs $(y \dot{\phi} \tilde{y})_{ii} = y_i \dot{\phi} \tilde{y}_i$ and $(\tilde{y} \dot{\phi} y)_{ii} = \tilde{y}_i \dot{\phi} y_i$.

Definition 18 (Indicator of an observed MIMO system). Let $h \in \mathcal{M}_{in}^{ax}[[\gamma, \delta]]^{q \times p}$ be the transfer function of a MIMO (max, +)-linear system. Let $u \in \mathcal{M}_{in}^{ax}[[\gamma, \delta]]^p$ and $y \in \mathcal{M}_{in}^{ax}[[\gamma, \delta]]^q$ be the observable input and output trajectories of the system. The indicator $I_{MO}(u, y)$ is a function:

$$I_{MO}(u, y) = \bigvee_{i=1}^q I_{SO}(u, y_i). \quad (7)$$

where $I_{SO}(u, y_i)$ is a modified version of the single output indicator:

$$I_{SO}(u, y_i) = \begin{cases} \text{false} & \text{if for } \tilde{y} = hu, \Sigma_\tau(y_i, \tilde{y}_i) = [0; 0], \\ \text{true} & \text{otherwise.} \end{cases}$$

More precisely:

$$\begin{aligned} \Sigma_\tau(y_i, \tilde{y}_i) &= [\mathcal{D}_{y_i \dot{\phi} \tilde{y}_i}(0); -\mathcal{D}_{\tilde{y}_i \dot{\phi} y_i}(0)] \\ &= [\mathcal{D}_{(y \dot{\phi} \tilde{y})_{ii}}(0); -\mathcal{D}_{(\tilde{y} \dot{\phi} y)_{ii}}(0)]. \end{aligned}$$

As for the indicator on system with a single output and since u is observed, I_{MO} first simulates the system to get the expected output \tilde{y} . Then, thanks to the computation of the right quotient of matrices between y and \tilde{y} , the distances between each y_i and \tilde{y}_i is computed as explained in Section 3.

Proposition 19. *The indicator $I_{MO}(u, y)$ is correct.*

Proof. I_{MO} returns true iff there exists at least one index i such that $I_{SO}(u, y_i)$ is true. But $I_{SO}(u, y_i)$ is correct as it is based on the computation of the time shift bounds $\Sigma_\tau(y_i, \tilde{y}_i)$ (see Proposition 16). Therefore, as long as the expected output of the system is the real output of the system I_{MO} will return false. \square

Example 20. Let the MIMO ($\max, +$)-linear system illustrated Figure 5, with the following state representation:

$$\begin{cases} X = \begin{pmatrix} \cdot & \cdot & \cdot & \cdot \\ \gamma^0\delta^2 & \cdot & \cdot & \gamma^0\delta^1 \\ \gamma^0\delta^2 & \cdot & \gamma^1\delta^1 & \cdot \\ \cdot & \cdot & \gamma^0\delta^1 & \cdot \end{pmatrix} X \oplus \begin{pmatrix} \gamma^0\delta^1 & \cdot \\ \cdot & \gamma^0\delta^3 \\ \cdot & \cdot \\ \cdot & \cdot \end{pmatrix} U, \\ Y = \begin{pmatrix} \cdot & \gamma^0\delta^3 & \cdot & \cdot \\ \cdot & \cdot & \cdot & \gamma^0\delta^1 \end{pmatrix} X. \end{cases}$$

and the transfer function:

$$h = \begin{pmatrix} \gamma^0\delta^8(\gamma^1\delta^1)^* & \gamma^0\delta^8(\gamma^1\delta^1)^* \\ \gamma^0\delta^5(\gamma^1\delta^1)^* & \gamma^0\delta^5(\gamma^1\delta^1)^* \end{pmatrix}.$$

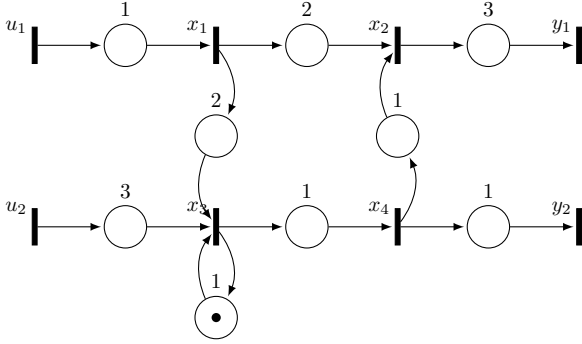

Figure 5: A MIMO ($\max, +$)-linear system

By giving the following input:

$$u = \begin{pmatrix} \gamma^0\delta^2 \oplus \gamma^1\delta^4 \oplus \gamma^3\delta^\infty \\ \gamma^0\delta^3 \oplus \gamma^1\delta^5 \oplus \gamma^3\delta^\infty \end{pmatrix},$$

the expected output is:

$$\tilde{y} = \begin{pmatrix} \gamma^0\delta^{11} \oplus \gamma^1\delta^{13} \oplus \gamma^2\delta^{14} \oplus \gamma^3\delta^\infty \\ \gamma^0\delta^8 \oplus \gamma^1\delta^{10} \oplus \gamma^2\delta^{11} \oplus \gamma^3\delta^\infty \end{pmatrix}.$$

Now, assume that there is a time failure generating a delay of 4 time units between transition x_1 and transition x_2 (the place between these transitions is then labeled with 6 time units instead of 2). The observed output is then:

$$y = \begin{pmatrix} \gamma^0\delta^{12} \oplus \gamma^1\delta^{14} \oplus \gamma^3\delta^\infty \\ \gamma^0\delta^8 \oplus \gamma^1\delta^{10} \oplus \gamma^2\delta^{11} \oplus \gamma^3\delta^\infty \end{pmatrix}.$$

Computations of $\tilde{y}\phi y$ and $y\phi\tilde{y}$ give for output y_1 :

$$(\tilde{y}\phi y)_{11} = \tilde{y}_1\phi y_1 = \gamma^0\delta^{-1} \oplus \gamma^1\delta^0 \oplus \gamma^2\delta^2 \oplus \gamma^3\delta^{+\infty},$$

$$(y\phi\tilde{y})_{11} = y_1\phi\tilde{y}_1 = \gamma^0\delta^0 \oplus \gamma^1\delta^1 \oplus \gamma^2\delta^3 \oplus \gamma^3\delta^{+\infty}.$$

So, $I_{SO}(u, y_1) = true$ because $\Sigma_\tau(y_1, \tilde{y}_1) = [0; 1]$. A time shift is detected for this output. About output y_2 , we obtain:

$$(\tilde{y}\phi y)_{22} = \tilde{y}_2\phi y_2 = \gamma^0\delta^0 \oplus \gamma^1\delta^1 \oplus \gamma^2\delta^3 \oplus \gamma^3\delta^{+\infty},$$

$$(y\phi\tilde{y})_{22} = y_2\phi\tilde{y}_2 = \gamma^0\delta^0 \oplus \gamma^1\delta^1 \oplus \gamma^2\delta^3 \oplus \gamma^3\delta^{+\infty}.$$

So, $I_{SO}(u, y_2) = false$ because $\Sigma_\tau(y_2, \tilde{y}_2) = [0; 0]$. There is no time shift detected for this output.

Finally, by Definition 18, $I_{MO}(u, y) = I_{SO}(u, y_1) \vee I_{SO}(u, y_2) = true \vee false = true$. The time failure is detected.

6 Conclusion

This paper introduces the problem of fault detection and diagnosis of TDES by the use of a ($\max, +$) algebraic approach. The use of ($\max, +$) to compute indicators for time shift failures in systems like assembly lines, transportation systems is very natural and relies on the residuation theory. The set of failure indicators that are defined here are fully characterized by ($\max, +$) operators and are proven to be correct as they rely on the computation of time shift bounds between two timed event flows. The proposed approach has been fully implemented with the `minmaxgd` C++ library.

This paper is a first step towards a complete diagnostic framework that covers ($\max, +$)-linear systems. Our aim is to extend the model by introducing fault models and then perform more complex diagnostic tasks like fault localisation and identification. The diagnosability question as well as the sensor placement problem will be also investigated within the diagnostic framework over ($\max, +$)-linear systems. In particular, one specific problem in this type of system is that faults can be compensated by synchronization phenomena so that they might totally be silent from a global point of view, and adding local sensors is then necessary.

Another lead to this work is to deal with systems that present time intervals for the duration of processes. In that case, one idea should be to work with bounds of the system behaviors, a fastest with all the minimal times of intervals and a slowest with all the maximal times. This can be very useful for systems where processes times are not exactly known or may vary.

References

- [Baccelli et al., 1992] Baccelli, F., Cohen, G., Olsder, G.J., and Quadrat, J.-P. (1992). *Synchronization and linearity: an algebra for discrete event systems*. Wiley and sons.
- [Bouyer et al., 2005] Bouyer, P., Chevalier, F., and D'Souza, D. (2005). Fault diagnosis using timed automata. In Sassone, V., editor, *Proceedings of the 8th International Conference on Foundations of Software Science and Computation Structures (FoSSaCS'05)*, volume 3441 of *Lecture Notes in Computer Science*, pages 219–233, Edinburgh, Scotland, UK. Springer.
- [Cohen et al., 1989] Cohen, G., Moller, P., Quadrat, J.-P., and Viot, M. (1989). Algebraic tools for the performance evaluation of discrete event systems. *Proceedings of the IEEE*, 77(1):39–85.
- [Cottenceau et al., 2000] Cottenceau, B., Lhommeau, M., Hardouin, L., and Boimond, J.-L. (2000). Data processing tool for calculation in dioid. In *5th International Workshop on Discrete Event Systems. WODES'00*. <http://www.istia.univ-angers.fr/~hardouin/outils.html>.
- [Dousson and Duong, 1999] Dousson, C. and Duong, T. V. (1999). Discovering chronicles with numerical time constraints from alarm logs for monitoring dynamic systems. In *IJCAI 99: Proceedings of the Sixteenth International Joint Conference on Artificial Intelligence*, pages 620–626, San Francisco, CA, USA.

- [Ghazel et al., 2009] Ghazel, M., Toguyéni, A., and Yim, P. (2009). State observer for des under partial observation with time petri nets. *Discrete Event Dynamic Systems*, 19(2):137–165.
- [Jiroveanu et al., 2013] Jiroveanu, G., Schutter, B., and Boel, R. (2013). *Taming Heterogeneity and Complexity of Embedded Control*, chapter The On-line Diagnosis of Time Petri Nets Based on Partial Orders, page 21. John Wiley & Sons.
- [Liu et al., 2014] Liu, B., Ghazel, M., and Toguyéni, A. (2014). Diagnosis of labeled time petri nets using time interval splitting. In *19th World Congress of The International Federation of Automatic Control*, pages 1784–1789.
- [MaxPlus, 1991] MaxPlus (1991). Second order theory of min-linear systems and its application to discrete event systems. In *Proceedings of the 30th IEEE Conference on Decision and Control. CDC'91*.
- [Pencolé and Subias, 2009] Pencolé, Y. and Subias, A. (2009). A chronicle-based diagnosability approach for discrete timed-event systems: Application to web-services. *Journal of Universal Computer Science*, 15(17):3246–3272.
- [Saddem and Philippot, 2014] Saddem, R. and Philippot, A. (2014). Causal temporal signature from diagnoser model for online diagnosis of discrete event systems. In *International Conference on Control, Decision and Information Technologies (CoDIT)*, pages 551–556.
- [Subias et al., 2014] Subias, A., Travé-Massuyès, L., and Corronc, E. L. (2014). Learning chronicles signing multiple scenario instances. In *19th World Congress of The International Federation of Automatic Control*, pages 10397–10402.
- [Tripakis, 2002] Tripakis, S. (2002). *Fault Diagnosis for Timed Automata*, pages 205–221. Springer Berlin Heidelberg, Berlin, Heidelberg.
- [Zaytoon and Lafortune, 2013] Zaytoon, J. and Lafortune, S. (2013). Overview of fault diagnosis methods for discrete event systems. *Annual Reviews in Control*, 37(2):308 – 320.